

**Queue-Safe Limited**  
**Portsmouth Technopole**  
**Kingston Crescent**  
**Portsmouth**  
**Hampshire PO2 8FA**

**Tel: +44(0)2392 658 222**  
**Fax: +44(0)2392 685 201**  
**Mob: +44(0)7884405879**

**W: [www.queue-safe.co.uk](http://www.queue-safe.co.uk)**  
**E: [info@queue-safe.co.uk](mailto:info@queue-safe.co.uk)**

### WIRING DIAGRAM FOR 4 HEATERS AND LIGHTS FOR PORTABLE STAND

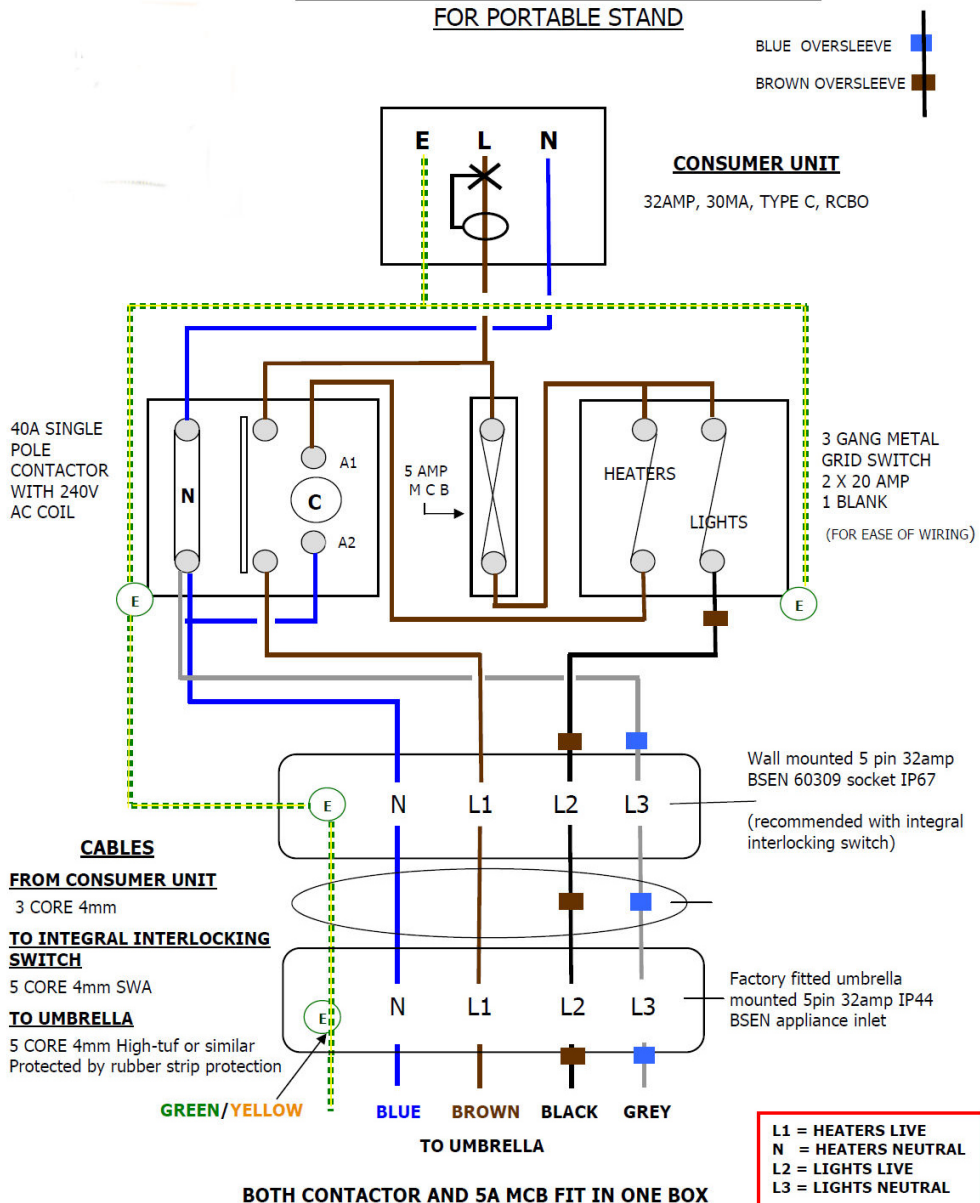

The installation must be carried out by a certified electrician

